

Laminar Flow Enclosures





Table of Contents

Product Protection You Can Count On	3	Ergonomic Technology Mounts	
Laminar Flow Enclosures At-a-Glance		Universal Kits for all Labconco Base Stands	17
Steps to Selecting a Clean Bench	4	Vertical Clean Bench	
Enclosure Types	5	Features & Benefits	18
Principles of Laminar Flow		Specifications & Ordering Information	19
Introduction	6	Filtered PCR Enclosure	
Horizontal vs. Vertical	7	Features & Benefits	20
Nexus™ Horizontal Clean Bench		Specifications & Ordering Information	21
Introduction	8	Vertical Clean Bench & Filtered PCR Enclosure	
Advanced Design	9	Dimensional Data	22
Features & Benefits	10	Accessories	23
Ordering Information	11	Telescoping Base Stand	24
Specifications	12	Hydraulic Base Stand	25
Dimensional Data	13	Non-Ventilated PCR Enclosure	
Accessories	14	Features & Benefits	26
Hydraulic Base Stand	16	Specifications, Ordering Information & Accessories	27

Product protection you can count on.

Critical applications require reliable, contamination-free spaces for handling sensitive, non-hazardous samples. Labconco laminar flow clean benches provide ISO Class 5 or better cleanroom cleanliness, ensuring your processes are protected.

Established in 1925, Labconco has a long history of delivering exceptional performance and quality products for critical environments. Labconco clean benches are no exception. Manufactured with quality materials, our clean benches offer reliability for any application.

With a variety of sizes across both horizontal and vertical designs and a broad selection of accessories, we have your application covered.

Don't chance your work. Let Labconco protect what matters most — your products.



Labconco Laminar Flow Enclosures

Steps to Selecting a Clean Bench

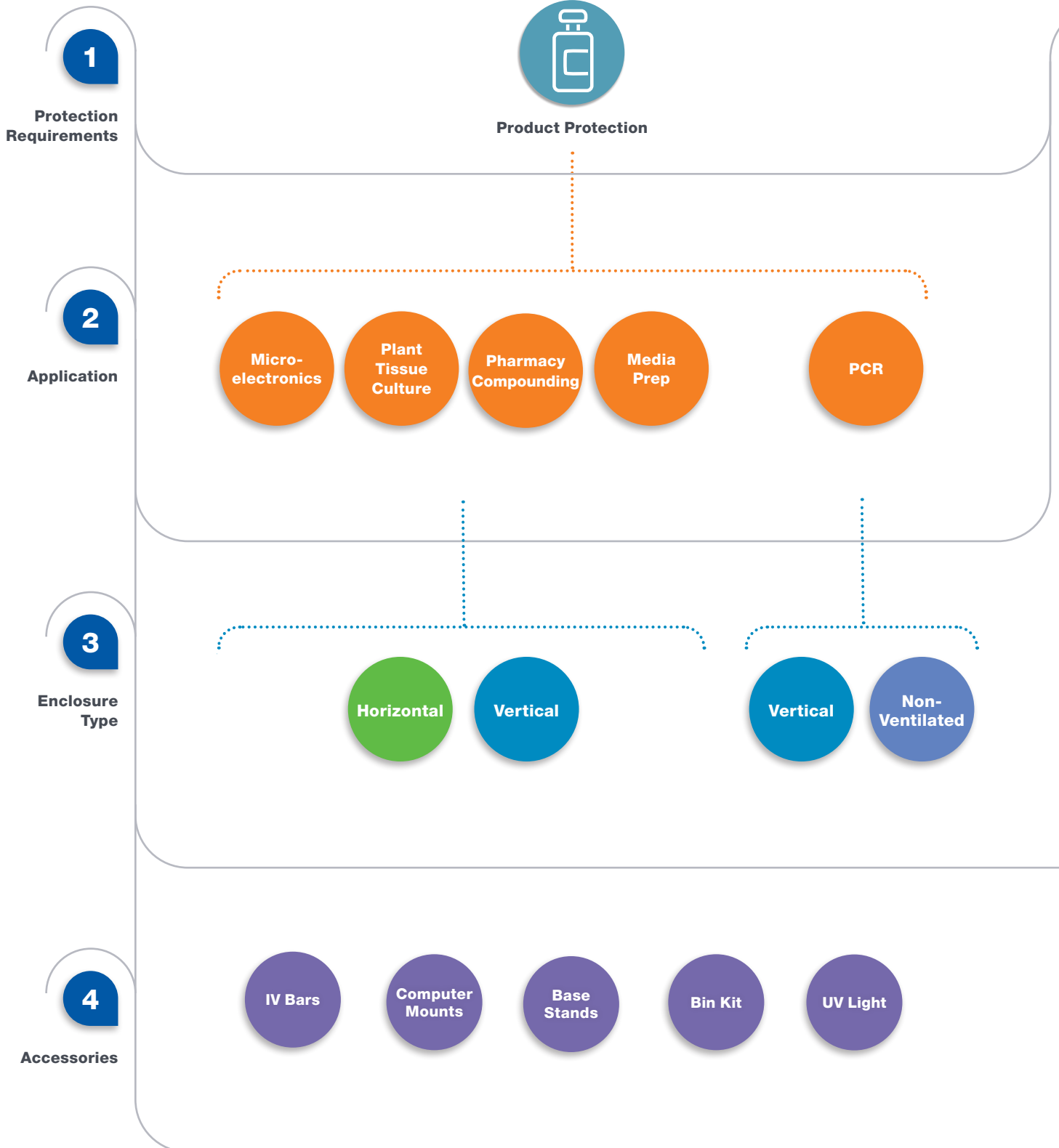

Labconco Laminar Flow Enclosures

Enclosure Types

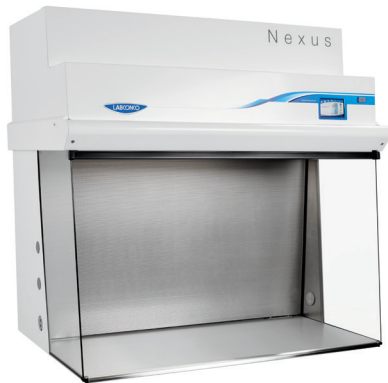

Nexus™ Horizontal Clean Bench



Vertical Clean Bench

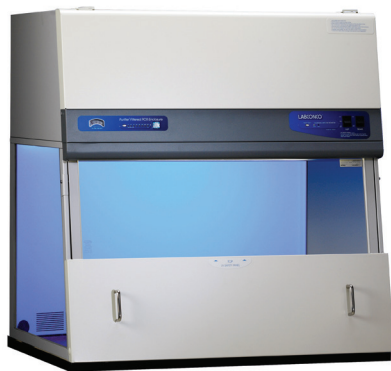

Filtered PCR Enclosure



Non-Ventilated PCR Enclosure



IV Bar



Technology Mounts



Base Stands

Principles of Laminar Flow

Introduction

Laminar Airflow

Laminar (unidirectional) airflow is moving air within a designated space that is uniform in both velocity and direction. When combined with High Efficiency Particulate Air (HEPA) filtration, laminar airflow creates exceptionally clean air.

Clean benches are the most common type of engineering control to employ HEPA filtered laminar flow and are found in many scientific, clinical, and industrial settings where product or sample protection is paramount. They are laboratory enclosures designed to carefully direct nearly particulate-free air across the work surface.

By design, clean benches protect items placed on the work surface from contamination. These types of enclosures are only used for non-hazardous (HD) work such as non-HD sterile injectable drug compounding, plant tissue culture, media preparation, microelectronics work, or medical device assembly.

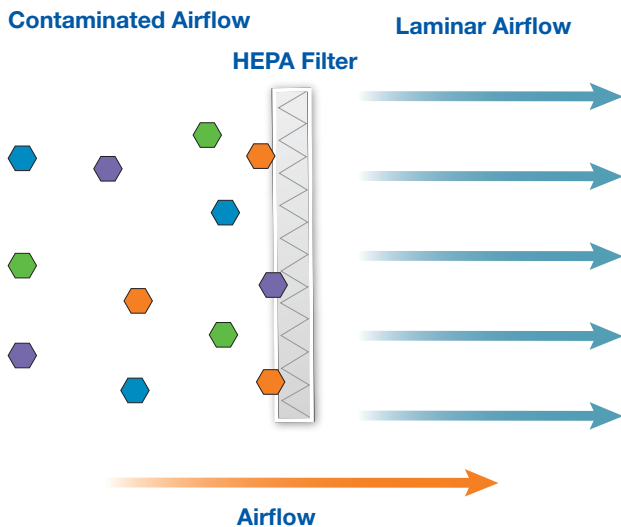

HEPA Filtration

During operation, room air is first drawn through a prefilter to trap large particles. Air then flows through a 99.99+% efficient HEPA filter to trap aerosols and other particulates from the room area. The resultant output is ISO Class 5 or better air cleanliness (ISO 14644-1). This airflow is directed across the entire work area as laminar flow. HEPA-filtered air minimizes cross contamination in the work area and provides a particulate-free work environment.

Principles of Laminar Flow

Horizontal vs. Vertical

Horizontal Clean Benches provide a large HEPA filtered area originating from a diffuser at the back wall. Air flows towards the user unobstructed. These models offer larger front openings and work areas compared to vertical models and do not have a front sash. The absence of a sash offers unrestricted movement to the top of the work area, ideal for hanging IV bags or accessing tall equipment. Horizontal models are typically mounted on base stands.

Vertical Clean Benches provide better protection for samples and equipment in crowded areas. A glass sash at the front of the enclosure directs HEPA filtered air downward through the work area, ensuring that the work area is fully bathed. The design of a vertical clean bench can provide an advantage over a horizontal clean bench by eliminating the risk of air obstruction between the diffuser and a critical activity. Vertical models are typically mounted on a base stand or benchtop.

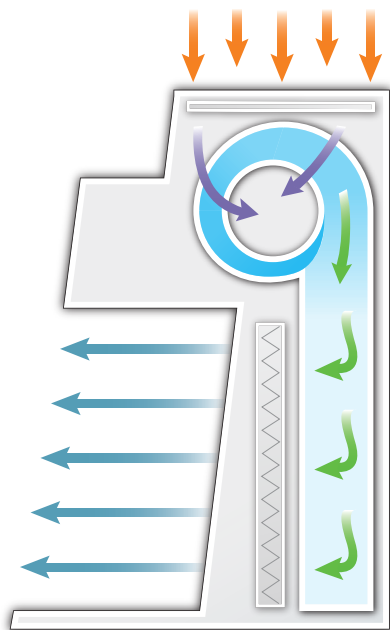

- ▶ Room Air
- ▶ Prefiltered, Negative Pressure Air
- ▶ Prefiltered, Positive Pressure Air
- ▶ HEPA Filtered, Positive Pressure Air

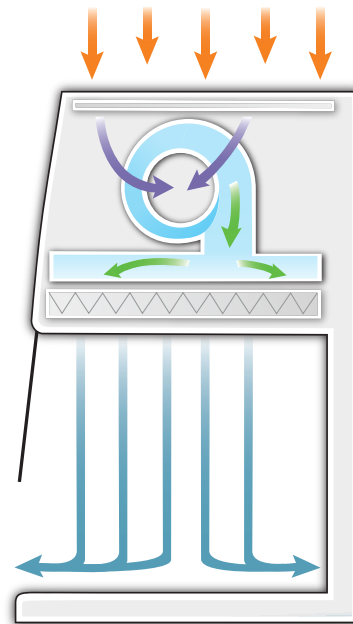

- ▶ Room Air
- ▶ Prefiltered, Negative Pressure Air
- ▶ Prefiltered, Positive Pressure Air
- ▶ HEPA Filtered, Positive Pressure Air

	Horizontal	Vertical
Protection	Product	Product
Air Quality	ISO Class 4	ISO Class 5
Access	Unobstructed Front Opening	Laminarity-enhancing Glass Sash
Interior Height	30"	25" or 30"
Work Surface	Integrated: Stainless Steel or PVC	Sold Separately: Stainless Steel or Epoxy
Application	Pharmacy Compounding, Seed & Plant, Microelectronics	Pharmacy Compounding, PCR

Nexus™ Horizontal Clean Bench

Introduction



The **Nexus Horizontal Clean Bench** rethinks everything you've come to know about laminar airflow enclosures. Designed to be efficient, intelligent and reliable, the Nexus protects your non-hazardous applications with horizontal unidirectional (laminar) ISO Class 4 air across the work area. Combined with an easily cleanable interior and CAP™ airflow, your work is always protected from contamination.

The **Nexus OS** gives full user control over the enclosure. The 5" touchscreen interface features an intuitive home screen for monitoring airflow and filter life. A quick swipe accesses everything else – from user preferences to system data logs and certification records.

Nexus™ Horizontal Clean Bench

Advanced Design



Complete Protection

- Maximum cleanability is achieved with easily wipeable, coved corners and tempered glass that stands up to any disinfectant
- Stainless steel models offer a full 304 stainless steel interior, work surface, and diffuser for maximum corrosion protection. The easily-removable diffuser allows for deep cleaning with ease
- Unidirectional ISO Class 4 airflow is 3rd party validated and cleaner than standard ISO Class 5 laminar airflow workstations
- A long-life HEPA filter (99.99+%) and easy-change prefilter keep your work area clean and lasting



Constant Airflow Profile™

The first of its kind, CAP™ technology delivers precision airflow within 2% of its calibration — at all times. Proprietary algorithms drive the electronically commutated motor (ECM blower) to deliver perfect airflow and quiet operation.



Pass-throughs & Connections

Dual cord pass-throughs and four laser-etched service fixture locations provide flexibility and maximum cleanability.

Nexus™ Horizontal Clean Bench

Features & Benefits



Superior clean air

Particle counts in the work area conform to ISO 14644-1 and 2 providing ISO Class 4 conditions.

Quality filtration

HEPA filters are 99.99+% efficient and provide ISO Class 4 air. 99.999% ULPA filters available.

Nexus OS™

5" touchscreen display provides status and performance information.

Constant Airflow Profile™

CAP technology monitors and maintains airflow as filters load to ensure samples are protected.

ECM blower

Advanced technology uses minimal energy, reduces noise and provides reliably constant airflow.

Optional UV light

Germicidal UV lamp (254 nm) with safety interlocked protection shade provides secondary decontamination.

Quality construction

Durable materials, including safety glass and steel, withstand routine disinfection.

Adaptive side panels

Allow passage of equipment cables and addition of service fixtures.

Night-Smart™

Reduces fan speed during off hours, conserving energy and helps maintain a clean work area.

Multiple configurations

'Standard' — epoxy coated steel interior with PVC work surface or 'Stainless Steel' — 304 Stainless Steel interior and work surface.

Nexus Operating System



Intuitive Software

Easy to use, familiar features allow quick access to the blower, light and UV functions.

Filter Monitor

HEPA filter life continuously displayed on home screen. Alerts when nearing end of use.

Practical Features

Includes experiment timer, user and admin passwords, display settings, certification logs and maintenance records.

Intelligent Display

Intuitive graphics ensure clear communication of operational status.

Alerts & Alarms

Full sentence visual and audible signals notify users of unsafe airflow conditions.

Connectivity

Easily export system performance records via the USB in CSV or PDF format for easy record keeping.

Nexus™ Horizontal Clean Bench

Ordering Information

Catalog Number Configurator:

Use this key to configure the seven digit catalog number to order your Nexus Horizontal Clean Bench.

5 3

Select the **WIDTH**. This is the third digit of your catalog number.

3 = 3' **4** = 4' **5** = 5' **6** = 6' **8** = 8'

Select the working **DEPTH** of your enclosure. This is the fourth digit of your catalog number.

0 = 21" **1** = 26"

Select the **MATERIAL** for the **INTERIOR, UV OPTION AND BASE STAND**. This is the fifth digit of your catalog number.

Standard Interior:

0 = Bench Only

2 = Includes UV

5 = Includes Base Stand

7 = Includes UV, Base Stand

Stainless Steel Interior:

1 = Bench Only

3 = Includes UV

6 = Includes Base Stand

8 = Includes UV, Base Stand

Select the **ELECTRICAL CONFIGURATION** and **PLUG TYPE**. These are the sixth and seventh digits of your catalog number.

00 = 115V, 15/20A, 60 Hz, with plug for North America

10 = 230V, 50/60 Hz, with plug for North America

30 = 230V, 50/60 Hz, with Schuko plug

40 = 230V, 50/60 Hz, with plug for China/Australia

50 = 230V, 50/60 Hz, with plug for Great Britain (UK)

70 = 230V, 50/60 Hz, with plug for India

Plug Configurations



115V, 15A
for North America
(3' and 4' widths)



115V, 20A
for North America
(5', 6' and 8' widths)



230V
for North America



230V
Schuko



230V
for China/Australia



230V
for Great Britain (UK)



230V
for India

Technical Specifications

Nominal Width/Work Surface Depth	Electrical Requirements (Dedicated, non-GFI outlet required)		Shipping Weight	Shipping Weight with Base Stand
	115V	230V		
3' x 21"			275 lbs. (125 kg)	335 lbs. (152 kg)
3' x 26"			290 lbs. (132 kg)	350 lbs. (159 kg)
4' x 21"	12A	6A	396 lbs. (180 kg)	474 lbs. (215 kg)
4' x 26"			411 lbs. (186 kg)	489 lbs. (222 kg)
5' x 21"			531 lbs. (241 kg)	648 lbs. (294 kg)
5' x 26"			564 lbs. (256 kg)	681 lbs. (309 kg)
6' x 21"	16A	8A	646 lbs. (293 kg)	783 lbs. (355 kg)
6' x 26"			679 lbs. (308 kg)	816 lbs. (370 kg)
8' x 21"			792 lbs. (359 kg)	948 lbs. (430 kg)
8' x 26"			822 lbs. (373 kg)	978 lbs. (444 kg)

Nexus™ Horizontal Clean Bench

Specifications



All models feature:

- Supply HEPA filter, 99.99% efficient at 0.3 microns, 99.999% @ 0.12 micron ULPA filter available
- Electronically Commutated Motor (ECM)
- Unidirectional, laminar airflow
- * Constant Airflow Profile™ (CAP) airflow monitoring system
- * Nexus Operating System and full color, 5" touchscreen featuring:
 - Simplified home screen for easy start up and shut down operations
 - Night-Smart™ for idling the blower when the system isn't in use
 - Full operational, maintenance and certification logs for detailed record keeping
 - Numeric and visual HEPA Filter Life graphic for easy HEPA filter monitoring
 - Password security lock (optional activation) that requires user or admin password to operate the cabinet
 - Status line for alarm conditions and alerts to warn when filter life diminishes to 20% and 10% before alarming at 0%
 - Interval/elapsed timer for experiment monitoring
 - UV light timer (on models with UV)
 - 8 Languages
- Spill-Stopper™ design protects HEPA filter from spills
- USB port for data record export
- Remote connectivity via Ethernet port
- Prefilters to help extend HEPA filter life
- Bright, glare-free LED lighting

* Labconco exclusive feature

- * Tempered safety glass and stainless steel side walls offer one utility pass-through port and two service fixture punch-outs
- * Electrical outlet(s)-ceiling mount, flat stainless steel cover
 - R side on 3' and 4' models, right and left side on 5'–8' models
 - 115V GFCI, double receptacle, maximum amperage draw 5A.
 - 230V, single receptacle, maximum amperage draw 3A.
- * 30.2" interior height
- Optic White epoxy-coated steel
- Nominal face velocity 85 fpm (0.43 m/s)
- 10' (3 m) power cord with plug
- Five year warranty

Models conform to the following standards:

- ISO Class 4 (Grade A) per ISO 14644–1 & 2
- UL Standard 61010–1
- CAN/CSA 22.2 No. 61010–1
- CE and UKCA Mark (230V models)

Options include:

- Standard Option: Epoxy coated steel interior and non-shedding PVC work surface
- Stainless Steel Option: 304 stainless steel interior and stainless steel work surface
- 21" or 26" interior depth
- 254 nm UV lamp with safety interlocked UV protection screen
- Unassembled, Optic White epoxy coated steel, non-welded telescoping base stand with leveling feet
- Hydraulic base stand: See page 16

All models require (not included):

- Supporting base (if non-welded stand option is not selected)



Nexus™ Horizontal Clean Bench

Dimensional Data

Nominal Width	A	B	21" Depth C-Interior	26" Depth D-Interior	21" Depth E-Exterior	26" Depth F-Exterior
3'	39.4" (100.1 cm)	37.0" (93.4 cm)	21.2" (53.8 cm)	26.2" (66.6 cm)	33.2" (84.3 cm)	38.2" (97.0 cm)
4'	51.4" (130.6 cm)	49.0" (124.5 cm)	21.2" (53.8 cm)	26.2" (66.6 cm)	33.2" (84.3 cm)	38.2" (97.0 cm)
5'	63.4" (161.0 cm)	61.0" (155.0 cm)	21.2" (53.8 cm)	26.2" (66.6 cm)	33.2" (84.3 cm)	38.2" (97.0 cm)
6'	87.4" (222.0 cm)	73.0" (185.4 cm)	21.2" (53.8 cm)	26.2" (66.6 cm)	33.2" (84.3 cm)	38.2" (97.0 cm)
8'	101.0" (256.6 cm)	98.6" (250.4 cm)	21.2" (53.8 cm)	26.2" (66.6 cm)	33.2" (84.3 cm)	38.2" (97.0 cm)

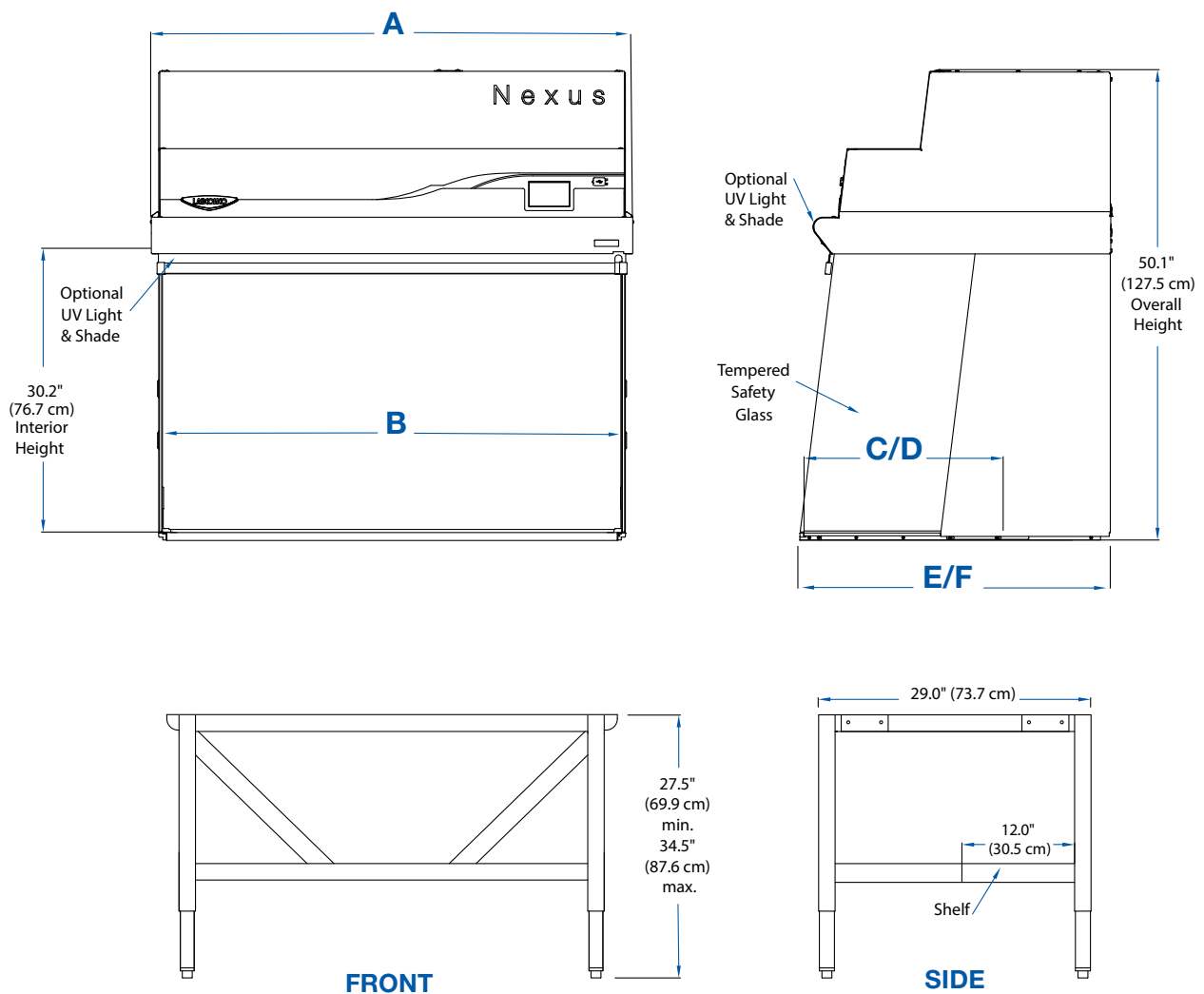

Nexus™ Horizontal Clean Bench

Accessories



IV Bar Kit. Includes IV bar, mounting hardware and four hangers (two short and two long). **Installation required.**

Catalog Number	Bench Width	Quantity Required	Shipping Weight
3697500	3'	1	4.0 lbs. (1.8 kg)
3697500	4'	1	4.0 lbs. (1.8 kg)
3695701	5'	1	4.0 lbs. (1.8 kg)
3697500	6'	2	6.0 lbs. (2.7 kg)
3697500	8'	2	6.0 lbs. (2.7 kg)

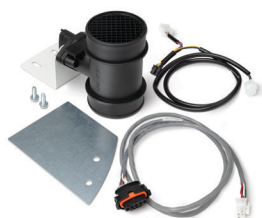

5322300—Nexus Airflow Sensor. Displays airflow velocity on touchscreen display. 5', 6' and 8' models require two sensors. Kit includes the sensor, all hardware needed and installation/calibration instructions. **Installation and certifier calibration required.** Shipping weight 2.0 lbs. (0.9 kg)



5321400—Nexus Remote Communication Board. Kit includes three dry contact relays, USB data output, RS-232 RJ45 data output and an Ethernet pass-through for easy Ethernet connection on the back of the horizontal clean bench. **Installation required.** Shipping Weight 1.0 lb. (0.5 kg)



8022000—Logic Cart. Compact storage for common supplies that takes up minimal space. Two inch diameter casters and handle cutouts allow easy movement while working. Right side compartments accommodate longer supplies like serological pipettes. Top compartment with front panel cutouts for wipes and gloves. Single storage drawer and open storage area. Constructed of corrosion-resistant white HDP and ABS that is easy to clean. Overall dimensions: 25.0" w x 19.0" d x 27.0" h (64 x 48 x 69 cm). Shipping weight 71 lbs. (32 kg)



5190200—Seismic Kit, Telescoping Base Stand. Secures telescoping base stand to the floor. Includes stainless steel brackets and hardware for attachment to stand. **Floor hardware and installation required.** Shipping weight 22 lbs. (10.0 kg)

5190100—Caster Kit. Optic White caster kit for telescoping base stand includes four 5" (12.7 cm) diameter, non-marking polyurethane casters with toe locks. **Installation required.** Shipping weight 10 lbs. (4.5 kg)

Nexus™ Horizontal Clean Bench

Accessories



5328800—Storage Bin Kit. Organization for syringes, IV bags and other consumables. Mount underneath the work surface of the Nexus. Kit includes one bin and bracket with mounting hardware. Internal bin dimensions: 10" w x 7" d x 6" h (25.4 x 17.8 x 15.2 cm). Compatible with Nexus telescoping base stand only. **Installation required.** Shipping weight 7.0 lbs. (3.2 kg)

Bench Width	Max Number of Kits
3'	2
4'	3
5'	4
6'	5
8'	7



Replacement Prefilters. Disposable prefilters trap large particles to extend HEPA filter life. MERV 8 rating. Labconco recommends changing every 3 months, depending on room cleanliness. **Installation required.**

Bench Width	Part Number(s) Required	Quantity Required
3'	5326800	2
4'	5326801	2
5'	5326800	2
	5326801	1
6'	5326801	3
8'	5326802	2
	5326801	2



3689700—Ergonomic Chair. 4-way articulating seat for personalized comfort. ISO Class 6 clean room compatible. Seat height adjusts from 19" to 26" (48–66 cm). Five-leg composite base with resistance casters. 24.4" (62.0 cm) wide. Black vinyl upholstery. ⚠ **WARNING:** Cancer - P65Warnings.ca.gov (California only). Shipping weight 43 lbs. (19.5 kg)



3746000—Adjustable Footrest. Ergonomic design reduces strain and fatigue while working. 18.5" w x 11.5" d x 8.0" h (47 x 29 x 20 cm). Shipping weight 6.0 lbs. (2.7 kg)

Nexus™ Horizontal Clean Bench

Hydraulic Base Stand

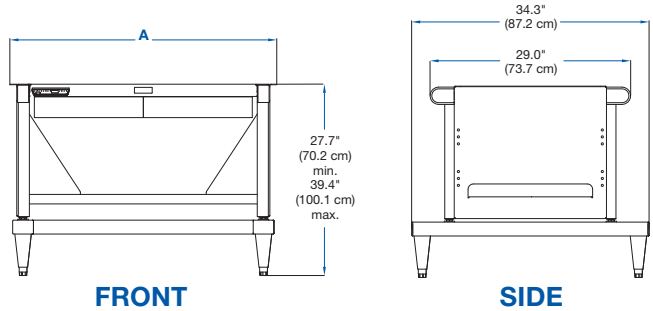

Nominal Width	A	Shipping Weight
3'	38.6" (98.0 cm)	178 lbs. (81 kg)
4'	50.6" (128.5 cm)	227 lbs. (103 kg)
5'	62.6" (159.0 cm)	261 lbs. (118 kg)
6'	74.6" (189.5 cm)	295 lbs. (134 kg)

Standard features

- Support loads up to 1,000 pounds (454 kg)
- Durable epoxy-coated Optic White steel frame
- Infinitely adjustable for working heights of 28–40" (71–101.6 cm)
- Four user-programmable memory positions
- Leveling feet or 5" (12.7 cm) diameter easy-clean casters with toe locks
- Front-accessible up/down switch, right or left side compatible
- Programmable safety stops to limit upper and lower travel

5190300—Seismic Kit, Hydraulic Base Stand. Secures hydraulic base stand to floor. Includes stainless steel brackets and hardware for attachment to stand. **Floor hardware and installation required.** Shipping weight 12 lbs. (5.4 kg)

Catalog Number Configurator:

Use this key to configure the seven digit catalog number to order your Nexus Hydraulic Base Stand.

5 1 8

Select the **TYPE OF FEET** required. This is the fourth digit of your catalog number.

0 = Leveling Feet 1 = Casters

Select the **NOMINAL STAND WIDTH**. This is the fifth digit of your catalog number.

3 = 3' 4 = 4' 5 = 5' 6 = 6'

Select the **ELECTRICAL CONFIGURATION** and **PLUG TYPE**. These are the sixth and seventh digits of your catalog number.

- 00 = 115V, 15A, 60 Hz, with plug for North America
- 10 = 230V, 50/60 Hz, with plug for North America
- 30 = 230V, 50/60 Hz, with plug for Schuko plug
- 40 = 230V, 50/60 Hz, with plug for China/Australia
- 50 = 230V, 50/60 Hz, with plug for Great Britain (UK)
- 70 = 230V, 50/60 Hz, with plug for India

Plug Configurations



115V, 15A
for North America



230V
for North America



230V
Schuko



230V
for China/Australia



230V
for Great Britain (UK)



230V
for India

Ergonomic Technology Mounts

Universal Kits for all Labconco Base Stands



Labconco offers several solutions for mounting computer equipment to our base stands. The PC Mount kit attaches to any Labconco base stand and provides a secure mounting platform for clamp style articulating arms.

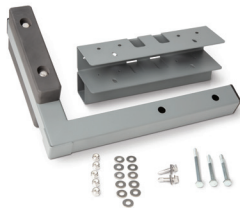

5315000—PC Mount kit. Provides a 4" w x 7" d (10.2 x 17.8 cm) area to secure most clamp style mounting systems. Mounts on either the right or left side of the base stand. Compatible with all Labconco base stands (SoLo, Hydraulic and Telescoping). Mounting arms not included. See part numbers 3997300, 3997400 and 3997900. **Installation required.** Shipping weight 9 lbs. (4.1 kg)



3997900—Ergotron® WorkFit-LX Monitor and Keyboard Arms. Polished Aluminum. Flexible design allows independent placement of the monitor and the keyboard. Capacity 7–25 lbs. (3.2–11.3 kg) PC Mount kit required and sold separately. **Installation required.** Shipping weight 35 lbs. (15.6 kg)



3997400—Ergotron® LX Desk Laptop Arm. Polished Aluminum. Allows independent placement of the laptop. Capacity 7–12 lbs. (3.2–5.4 kg) PC Mount kit required and sold separately. **Installation required.** Shipping weight 15 lbs. (6.8 kg)

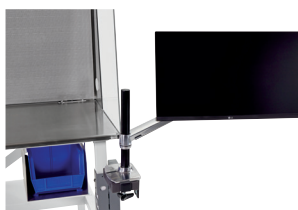

3997300—Ergotron® LX Desk Monitor Arm. Polished Aluminum. Allows independent placement of the monitor or tablet. Capacity 7–25 lbs. (3.2–11.3 kg) Tablet case not included. PC Mount kit required and sold separately. **Installation required.** Shipping weight 11.2 lbs. (5.1 kg)



Vertical Clean Bench

Features & Benefits

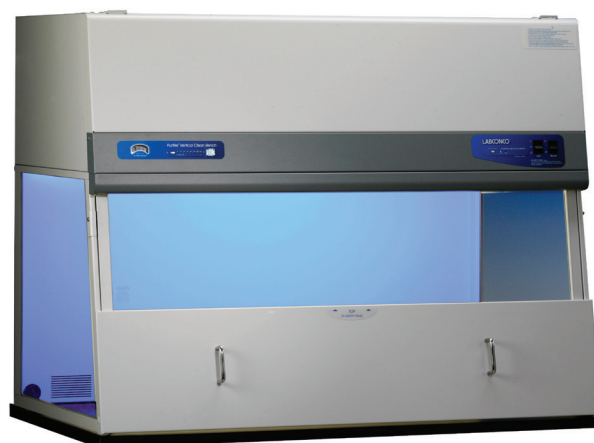

HEPA filtration

99.99+% efficient at 0.3 microns.

ISO Class 5 (Grade A) air quality

Particle counts in the work area conform to ISO 14644-1 and 2.

Differential pressure gauge

Indicates pressure across the HEPA filter and plenum to help determine HEPA filter loading.

Utility ports

Two utility ports allow passage of tubing or electrical cords. Plugs are provided to seal the ports when not in use.

Variable speed blower

Solid state control allows adjustment to extend filter life.

UV light option

Optional 254 nm ultraviolet lamp with safety interlocked protection panel and UV timer.

Guardian™ Airflow Monitor option

Alerts the user to airflow velocities outside of preset range.

Disposable prefilters

Traps large particles to extend the life of the HEPA filter.

Tempered safety glass sash

10° angled sash for less glare and more comfortable viewing. Pivots upward and canlocks open for loading and cleaning.

Solid Epoxy or Stainless Steel Work Surfaces

Sold separately. See page 23 for ordering information.

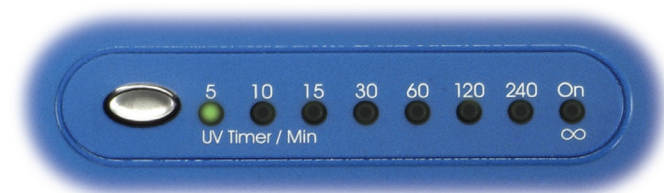

Vertical Clean Bench

Specifications & Ordering Information

All models feature:

- Vertical laminar flow
- Supply HEPA filter, 99.99% efficient at 0.3 microns
- Disposable prefilter
- Nominal downflow velocity of 40–55 fpm (0.2–0.27 m/s)
- Variable speed built-in blower with motorized impeller and solid state control
- Differential pressure gauge
- Air diffuser
- UV-resistant, Glacier White and Slate Gray epoxy-coated aluminum and steel construction
- UV-opaque and resistant 1/4" thick tempered safety glass sash and sides
- Fluorescent light
- Light and blower switches
- 9.4" (23.9 cm) sash opening on 2–4' models
- 11.6" (29.5 cm) sash opening on 6' models
- Ergonomic 10° angled and hinged sash that pivots upward, locks to a loading height of 20" (30" for 6' models) and has wiping seals to promote ISO Class 5 conditions
- Two, 1.5" utility pass-through ports, right and left rear wall
- One year warranty

Models conform to the following standards:

- ISO Class 5 (Grade A) per ISO 14644–1 & 2
- UL Standard 61010–1
- CAN/CSA 22.2 No. 61010–1
- CE and UKCA Mark (230V models)

Option includes:

- Guardian Airflow Monitor that continuously monitors downflow airflow and has two LED lights to indicate when airflow is within or outside set point range
- 254 nm UV lamp with 3-way switch (fluorescent, UV and off) and safety interlocked protection panel. Variable timer with eight settings from 5, 10, 15, 30, 60, 120, 240 minutes to continuous

All models require (not included):

- Supporting work surface (see page 23) or use existing bench top
- Supporting base stand (see page 24/25) or place on existing casework

Catalog Number Configurator:

Use this key to configure the seven digit catalog number to order your Vertical Clean Bench.

3

Select the **WIDTH** of your enclosure. These are the second to fifth digit of your catalog number.

9702 = 2' 9703 = 3' 9704 = 4' 6606 = 6'

Select the **ELECTRICAL CONFIGURATION**. This is the sixth digit of your catalog number.

0 = 115V, 15A, 60 Hz, with plug for North America
2 = 230V, 10A, 50/60 Hz, international configuration*

Select the **CONFIGURATION** for your enclosure. This is the seventh digit of your catalog number.

0 = Basic
1 = UV Light
3 = Airflow Monitor
4 = UV Light, Airflow Monitor

*Power cord not included

Plug Configurations



115V, 15A
for North America



Filtered PCR Enclosure

Features & Benefits

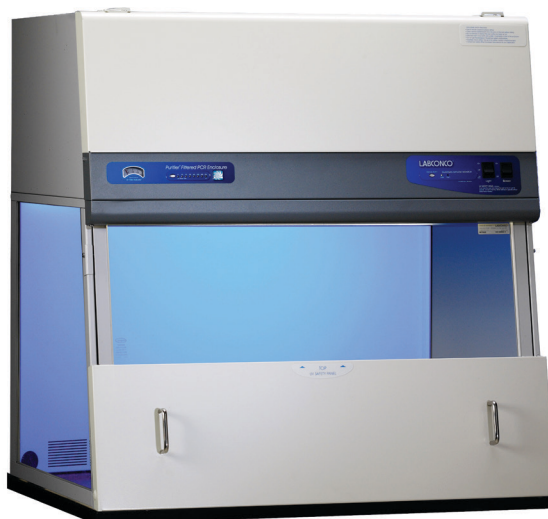

HEPA filtration

99.99+% efficient at 0.3 microns.

ISO Class 5 (Grade A) air quality

Particle counts in the work area conform to ISO 14644-1 and 2.

UV light

254 nm ultraviolet lamp with safety interlocked protection panel and UV timer.

Differential pressure gauge

Indicates pressure across the HEPA filter and plenum to help determine HEPA filter loading.

Utility ports

Two utility ports allow passage of tubing or electrical cords. Plugs are provided to seal the ports when not in use.

Guardian™ Airflow Monitor option

Alerts the user to airflow velocities outside of preset range.

Variable speed blower

Solid state control allows adjustment to extend filter life.

Disposable prefilters

Traps large particles to extend the life of the HEPA filter.

Tempered safety glass sash

10° angled sash for less glare and more comfortable viewing. Pivots upward and can lock open for loading and cleaning.

Solid Epoxy or Stainless Steel Work Surfaces

Sold separately. See page 23 for ordering information.

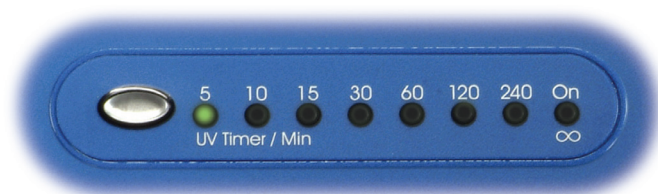

Filtered PCR Enclosure

Specifications & Ordering Information

All models feature:

- Vertical laminar flow
- Supply HEPA filter, 99.99% efficient at 0.3 microns
- 254 nm UV lamp with 3-way switch (fluorescent, UV and off) and safety interlocked protection panel. Variable timer with eight settings from 5, 10, 15, 30, 60, 120, 240 minutes to continuous
- Disposable prefilter
- Nominal downflow velocity of 40–55 fpm (0.2–0.27 m/s)
- Variable speed built-in blower with motorized impeller and solid state control
- Differential pressure gauge
- Air diffuser
- UV-resistant, Glacier White and Slate Gray epoxy-coated aluminum and steel construction
- UV-opaque and resistant 1/4" thick tempered safety glass sash and sides
- Fluorescent lamp
- Light and blower switches
- Two, 1.5" utility pass-through ports, right and left rear wall
- 9.4" (23.9 cm) sash opening

- Ergonomic 10° angled and hinged sash that pivots upward, locks to a loading height of 20" (30" for 6' models) and has wiping seals to promote ISO Class 5 conditions
- One year warranty

Models conform to the following standards:

- ISO Class 5 (Grade A) per ISO 14644–1 & 2
- UL Standard 61010–1
- CAN/CSA 22.2 No. 61010–1
- CE and UKCA Mark (230V models)

Option includes:

- Guardian Airflow Monitor that continuously monitors downflow airflow and has two LED lights to indicate when airflow is within or outside set point range

All models require (not included):

- Supporting work surface (see page 23) or use existing bench top
- Supporting base stand (see page 24/25) or place on existing casework

Catalog Number Configurator:

Use this key to configure the seven digit catalog number to order your Filtered PCR Enclosure.

3 9 7 0

Select the **WIDTH** of your enclosure. This is the fifth digit of your catalog number.

2 = 2' 3 = 3' 4 = 4'

Select the **ELECTRICAL CONFIGURATION**. This is the sixth digit of your catalog number.

0 = 115V, 15A, 60 Hz, with plug for North America
2 = 230V, 10A, 50/60 Hz, International Configuration*

Select the **AIRFLOW MONITOR OPTION** for your enclosure. This is the seventh digit of your catalog number.

2 = Basic
5 = Airflow Monitor

*Power cord not included

Plug Configurations



115V, 15A
for North America



Vertical Clean Bench & Filtered PCR Enclosure

Dimensional Data

	2'	3'	4'	6'
A	24.0" (61.0cm)	36.0" (91.4 cm)	48.0" (121.9 cm)	72.0" (182.9 cm)
B	22.8" (57.9 cm)	34.8" (88.4 cm)	46.8" (118.9 cm)	70.8" (179.8 cm)

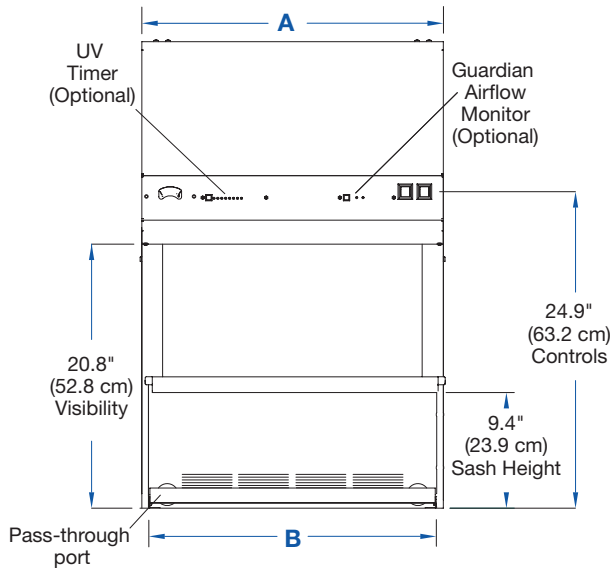

FRONT (2'-4' Models)

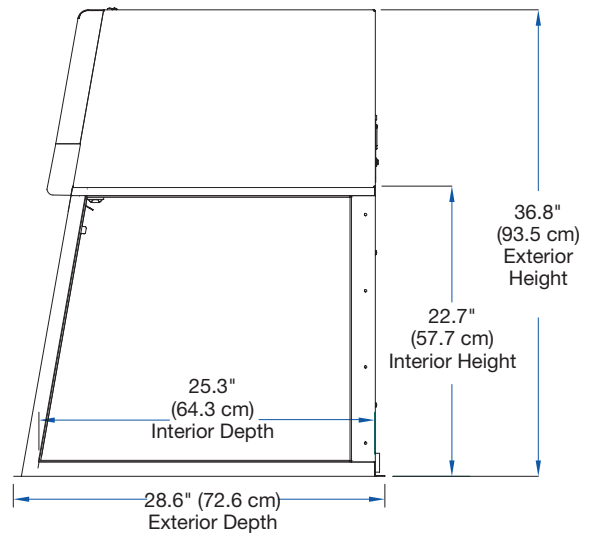

SIDE (2'-4' Models)

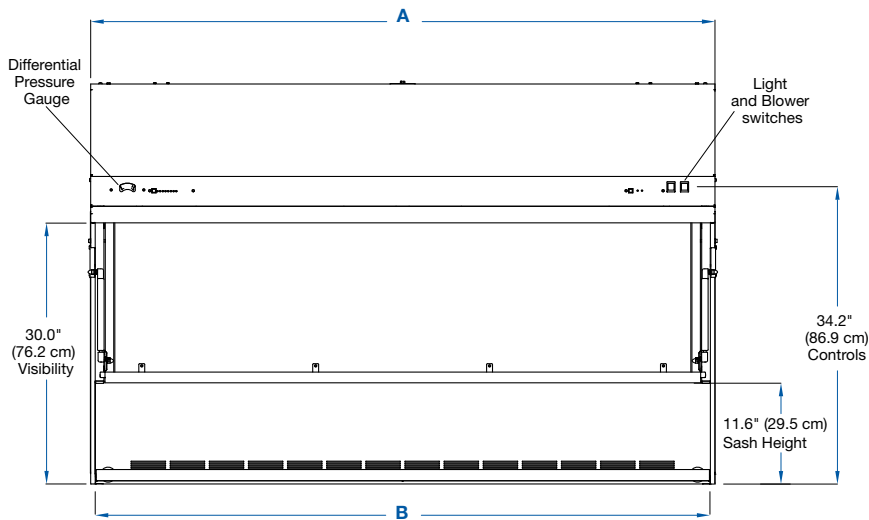

FRONT (6' Models)

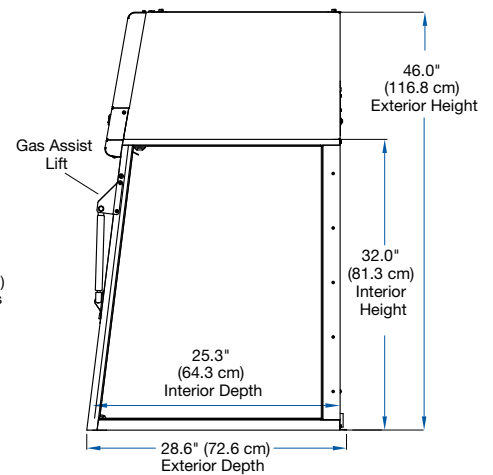

SIDE (6' Models)

Vertical Clean Bench & Filtered PCR Enclosure

Accessories

3689700—Ergonomic Chair.

4-way articulating seat for personalized comfort. ISO Class 6 clean room compatible. Seat height adjusts from 19" to 26" (48–66 cm). Five-leg composite base with resistance casters, 24.4" (62.0 cm) wide. Black vinyl upholstery. **⚠ WARNING:** Cancer - P65Warnings.ca.gov (California only). Shipping weight 43 lbs. (19.5 kg)



Disposable Prefilters.

Corrugated paper prefilters trap large particles to extend HEPA filter life. Labconco recommends replacing the prefilter every three months. One each.



Catalog Number	For use with	Quantity Required
3935700	2' Vertical Clean Bench	1
3935701	3' Vertical Clean Bench	1
3935702	4' Vertical Clean Bench	1
3935701	6' Vertical Clean Bench	2

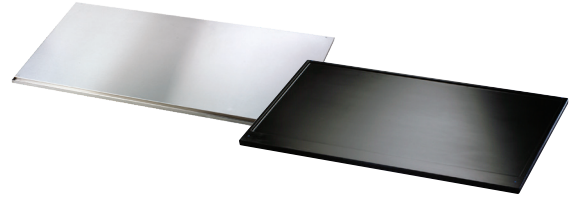

Solid Epoxy and Stainless Steel Work Surfaces. Black, chemical resistant epoxy work surface is dished to contain spills. Type 304, 18 ga. stainless steel work surfaces have a 1" deep spill trough.

Catalog Number	Size and Material	Dimensions	Shipping Weight
3909900	2' - Epoxy	24.0" w x 29.0" d x 1.0" h (61 x 73.7 x 2.5 cm)	66 lbs. (30 kg)
3909901	3' - Epoxy	36.0" w x 29.0" d x 1.0" h (91.4 x 73.7 x 2.5 cm)	100 lbs. (45 kg)
3909902	4' - Epoxy	48.0" w x 29.0" d x 1.0" h (121.9 x 73.7 x 2.5 cm)	110 lbs. (50 kg)
3909910	6' - Epoxy	72.0" w x 29.0" d x 1.0" h (182.8 x 73.7 x 2.5 cm)	150 lbs. (68 kg)
3970602	2' - SS	24.0" w x 29.0" d x 0.8" h (61.0 x 73.7 x 2.0 cm)	88 lbs. (40 kg)
3970603	3' - SS	36.0" w x 29.0" d x 0.8" h (91.4 x 73.7 x 2.0 cm)	109 lbs. (49 kg)
3970604	4' - SS	48.0" w x 29.0" d x 0.8" h (121.9 x 73.7 x 2.0 cm)	138 lbs. (63 kg)
3975602	6' - SS	72.0" w x 29.0" d x 0.8" h (182.8 x 73.7 x 2.0 cm)	180 lbs. (82 kg)



IV Bar Kit. Support intravenous solution bottles and bags. Include IV bar, mounting hardware, four hangers and installation instructions. **Installation required.**

Catalog Number	For use with	Shipping Weight
3721000	2' Vertical Clean Bench	4.0 lbs. (1.8 kg)
3721001	3' Vertical Clean Bench	6.0 lbs. (2.7 kg)
3721002	4' Vertical Clean Bench	8.0 lbs. (3.6 kg)
3721004	6' Vertical Clean Bench	10.0 lbs. (4.5 kg)

3746000—Adjustable

Footrest. Ergonomic design reduces strain and fatigue while working. 18.5" w x 11.5" d x 8.0" h (47 x 29 x 20 cm). Shipping weight 6.0 lbs. (2.7 kg)



8022000—Logic Cart.

Compact storage for common supplies that takes up minimal space. Constructed of corrosion-resistant white HDP and ABS that is easy to clean. Overall dimensions: 25.0" w x 19.0" d x 27.0" h (64 x 48 x 69 cm). Shipping weight 71 lbs. (32 kg)



Vertical Clean Bench & Filtered PCR Enclosure

Telescoping Base Stand



Standard Features

- Models with fixed feet support loads up to 4,000 pounds (1814 kg). Models with casters support loads up to 1,000 pounds (454 kg)
- Durable 1.75" (4.4 cm) tubular, Glacier White, epoxy-coated steel frame. Models 3' wide and larger have rear crossbar supports
- Telescoping legs are adjustable to eight height positions in 1" increments from 27.5" to 34.5" (69.9–87.6 cm)
- Available with fixed leveling feet or 5" (12.7 cm) diameter, toe-locking, non-marking polyurethane casters with bearings for quiet operation. Casters add 7"–11" (18–28 cm) to the overall depth of the base stand.
- ADA-compliant

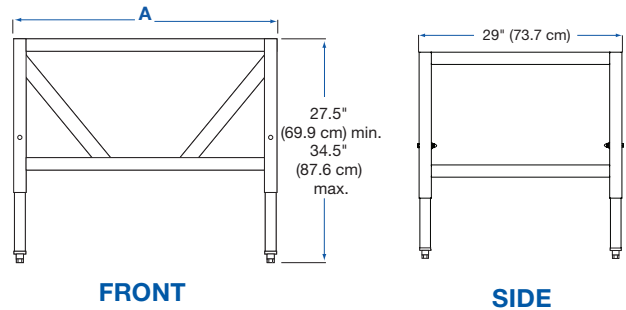

Catalog Number		Nominal Width	A	Shipping Weight
Fixed Feet	With Casters			
3746700	3746710	2'	24.0" (60.0 cm)	85 lbs. (39 kg)
3746701	3746711	3'	36.0" (91.4 cm)	110 lbs. (50 kg)
3746702	3746712	4'	48.0" (121.9 cm)	120 lbs. (55 kg)
3746704	3746714	6'	71.0" (180.3 cm)	130 lbs. (59 kg)

Optional Accessory Shelves. Glacier White, epoxy-coated, 16 gauge steel. Designed to hook on the lower rear horizontal cross member of the Telescoping Base Stand. Provides storage space for wipes, cleaning agents, gloves and other miscellaneous laboratory apparatus. One each. **Installation required.**

Nominal Width	Catalog Number	Shelf Width x Depth	Shipping Weight
2'	3811100	20.4" x 9.9" (51.8 x 25.1 cm)	9 lbs. (4 kg)
3'	3811001	32.4" x 9.9" (82.3 x 25.1 cm)	12 lbs. (5 kg)
4'	3811102	44.4" x 9.9" (112.8 x 25.1 cm)	15 lbs. (7 kg)
6'	3811104	68.4" x 9.9" (173.7 x 25.1 cm)	23 lbs. (10 kg)

3730500—Caster Kit. For converting telescoping base stands with fixed feet to mobile stands. Kit includes four 5" (12.7 cm) dia., polyurethane casters with toe locks. Load rating for each caster is 250 lbs. Casters add 7"–11" (18–28 cm) to the overall depth of the base stand. **Installation required.** Shipping weight 22 lbs. (9.8 kg)

Vertical Clean Bench & Filtered PCR Enclosure

Hydraulic Base Stand



Standard Features

- Support loads up to 1,000 pounds (454 kg)
- Durable 1.75" (4.4 cm) tubular, Glacier White epoxy-coated steel frame with rear crossbar supports. Sub-frame is 2.0" x 3.0" (5.1 x 7.6 cm)
- Height is infinitely adjustable from 25.5" to 33.5" (64.8–85.1 cm)
- Epoxy-coated feet with levelers
- Electric models include front-accessible up/down switch
- Manual models include front-accessible hand crank. The handle may be disengaged and folded under, out of the way, when not in use
- ADA-compliant

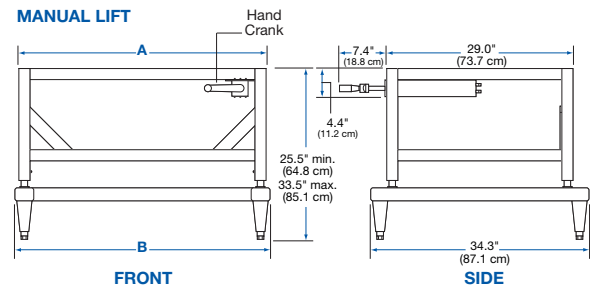
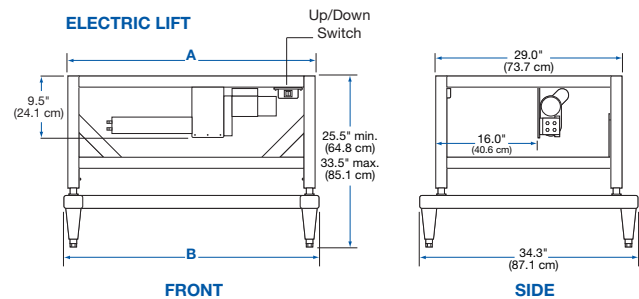

Catalog Number	Nominal Width	Description	Shipping Weight
3780300		Electric. 115V, 60 Hz, 2.4A	
3780303*	3'	Electric. 230V, 50/60 Hz, 0.8A	105 lbs. (48 kg)
3780400		Manual	
3780301		Electric. 115V, 60 Hz, 2.4A	
3780304*	4'	Electric. 230V, 50/60 Hz, 0.8A	175 lbs. (79 kg)
3780401		Manual	
3780302		Electric. 115V, 60 Hz, 2.4A	
3780305*	6'	Electric. 230V, 50/60 Hz, 0.8A	240 lbs. (109 kg)
3780402		Manual	

Nominal Width	A	B
3'	36.0" (91.4 cm)	37.2" (94.5 cm)
4'	48.0" (121.9 cm)	49.2" (125.0 cm)
6'	72.0" (182.9 cm)	73.2" (185.9 cm)

3784000—Caster Kit. Includes four 5" (12.7 cm) diameter, non-marking polyurethane casters with toe locks. Load rating for each caster is 250 pounds. Casters add 2.5"–7" (6.4–17.8 cm) to depth of enclosure. **Installation required.** 10 lbs. (4.5 kg)

*International Configuration. Power cord not included.

Non-Ventilated PCR Enclosure

Features & Benefits



Circulation-free work area

Designed to reduce cross contamination.

Glare-free lighting

Provides comfortable illumination inside the enclosure.

Utility Ports

Two utility ports allow passage of tubing and electrical cords from equipment inside the enclosure. Plugs are provided to seal the ports when not in use.

UV light

254 nm ultraviolet lamp with safety interlocked protection panel and UV timer.

Electrical outlet

Duplex outlet located inside the enclosure. Powered by the front mounted switch.

Work Surface and Base Stand Available.

See page 27 for ordering information.

Light switch

The 3-way light switch powers the fluorescent and UV light, but only one at a time, helping to protect the operator from inadvertent UV exposure.

Tempered safety glass sash

10° angled sash for less glare and closer, more comfortable viewing. Pivots upward and can lock open for loading and cleaning.

UV timer

Provides timed UV light exposure on models with UV lamp. Operator may select from eight settings.

Dimensional Data

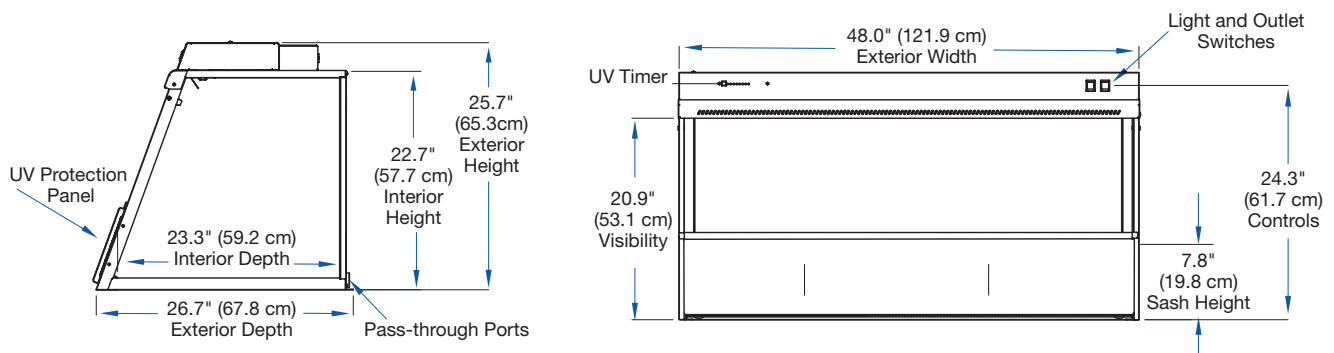

Non-Ventilated PCR Enclosure

Specifications, Ordering Information & Accessories

Model features:

- UV-resistant, Glacier White and Slate Gray epoxy-coated aluminum and steel construction
- UV-opaque and resistant, 1/4" thick tempered safety glass sash and sides
- 7.8" sash opening
- Ergonomic 20° angled and hinged sash that pivots upward, locks to a loading height of 20" and has wiping seals to reduce cross contamination
- Protection panel with UV light interlock to close the sash opening
- Fluorescent light
- Interior electrical receptacle
- 254 nm UV lamp with 3-way switch (fluorescent, UV and off) and safety interlocked protection panel. Variable timer with eight settings from 5, 10, 15, 30, 60, 120, 240 minutes to continuous.

- Front-mounted switches for light (3-way: fluorescent, UV, off) and auxiliary electrical receptacle
- Two 1.5" utility pass-through ports, R and L rear wall
- One year warranty

Model conforms to the following standards:

- UL Standard 61010-1
- CAN/CSA 22.2 No. 61010-1
- CE and UKCA Mark (230V models)
- ADA Compliant

Model requires:

- Supporting work surface (see below) or use existing bench top
- Supporting base stand (see below) or place on existing casework

Catalog Number	Nominal Width	Electrical Requirements	Shipping Weight
3952400	4 feet	115 volts, 60 Hz, 10 amps	175 lbs. (79 kg)
3952420*		230 volts, 50/60 Hz, 5 amps	

*International Configuration. Power cord not included



Telescoping Base Stand. Epoxy-coated steel. Adjust in 1" (2.5 cm) increments from 27.5" to 34.5" (69.9–87.6 cm). Available with fixed leveling feet or casters.

Catalog Number		Nominal Width	Shipping Weight
Feet Fixed	With Casters	4'	115 lbs. (52 kg)
3747002	3747012		



3908402—Solid Epoxy Dished Work Surface. Black, chemical-resistant, epoxy work surface is designed to fit the dimensions of the Non-Ventilated PCR Enclosure and is dished to help contain spills. Shipping weight 96 lbs. (44 kg)



**Visit labconco.com to request information
for all Labconco products.**

LABCONCO CORPORATION

8811 Prospect Avenue
Kansas City, MO 64132

(800) 821-5525 | (816) 333-8811

labconco.com

©2023 LABCONCO CORPORATION

Product design subject to change without notice.

3-40-7/21/2023

